

2.1 types of images

real image

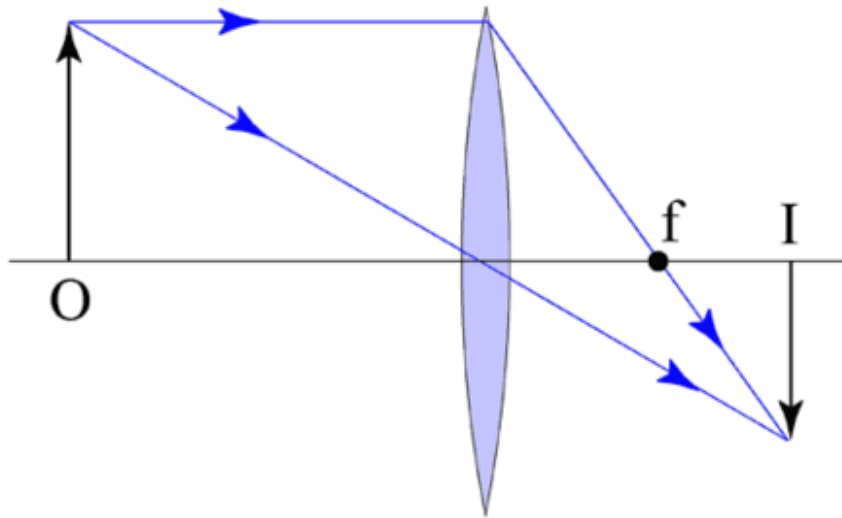

outgoing light rays from an optical element converge in a single point

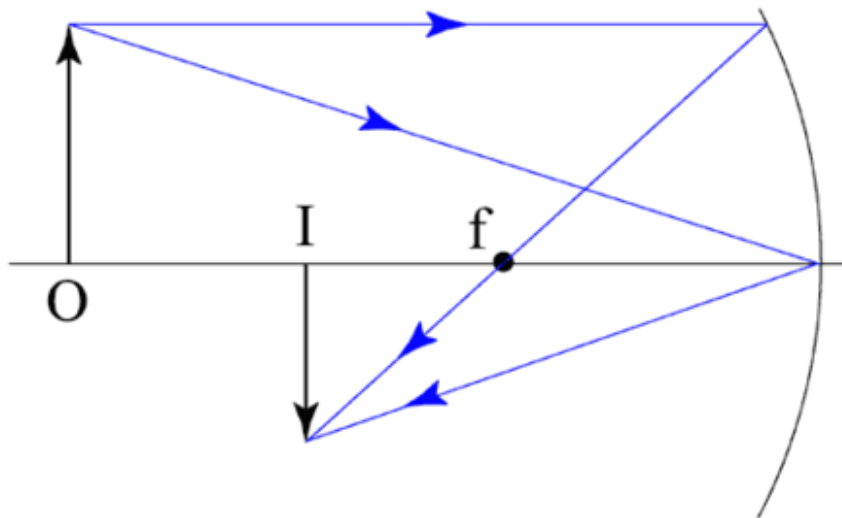

2.1 types of images

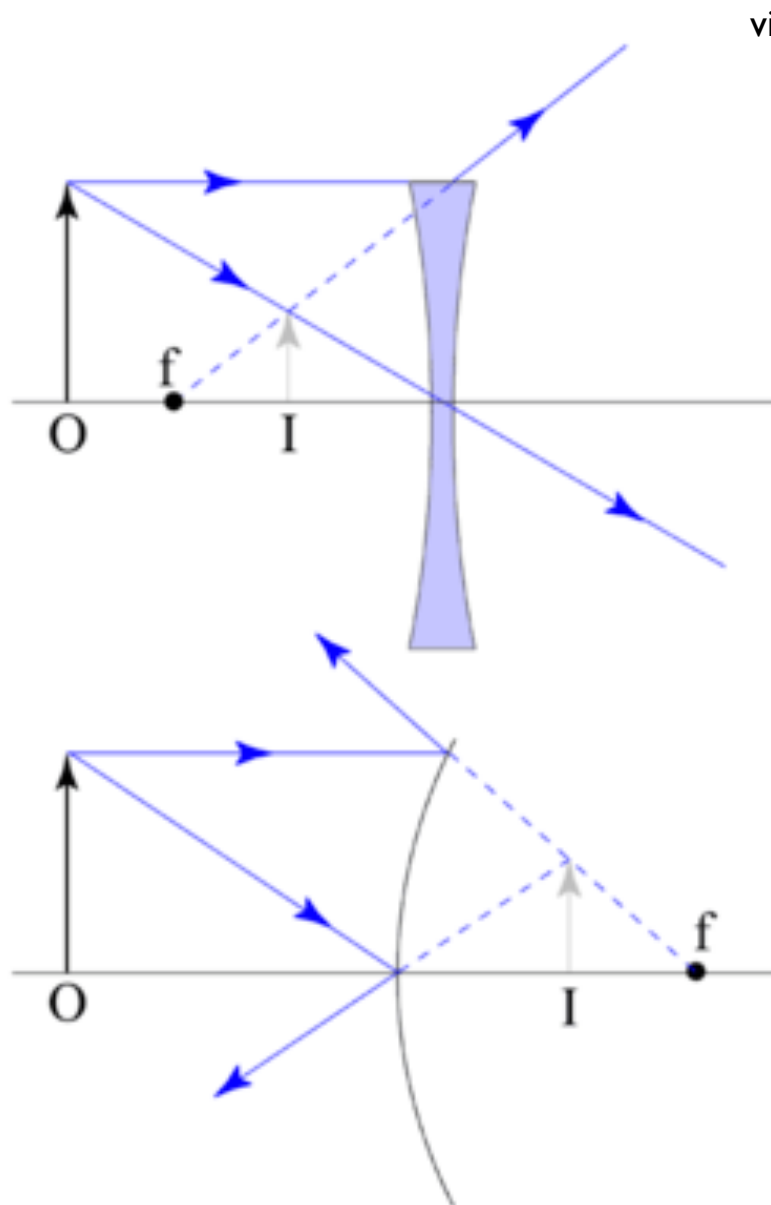

outgoing light rays from an optical element actually never converge

2.2 plane mirror

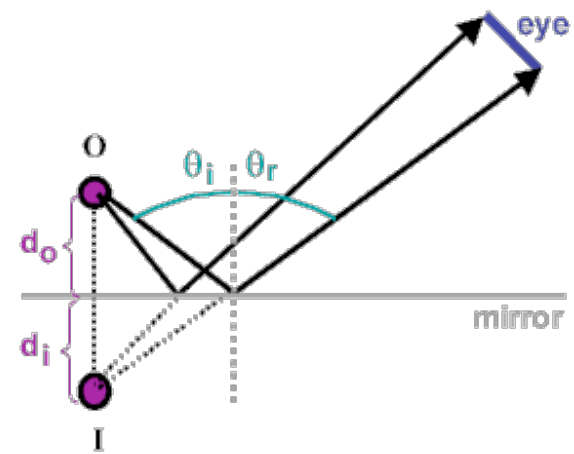
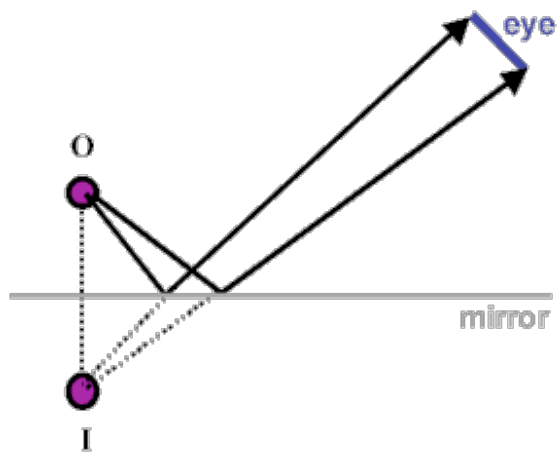

2.2 plane mirror

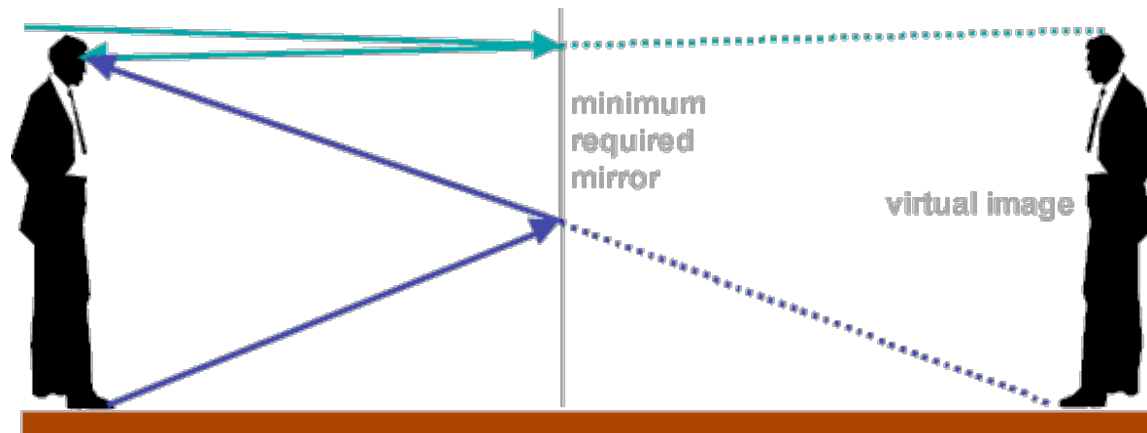

2.3 spherical mirror

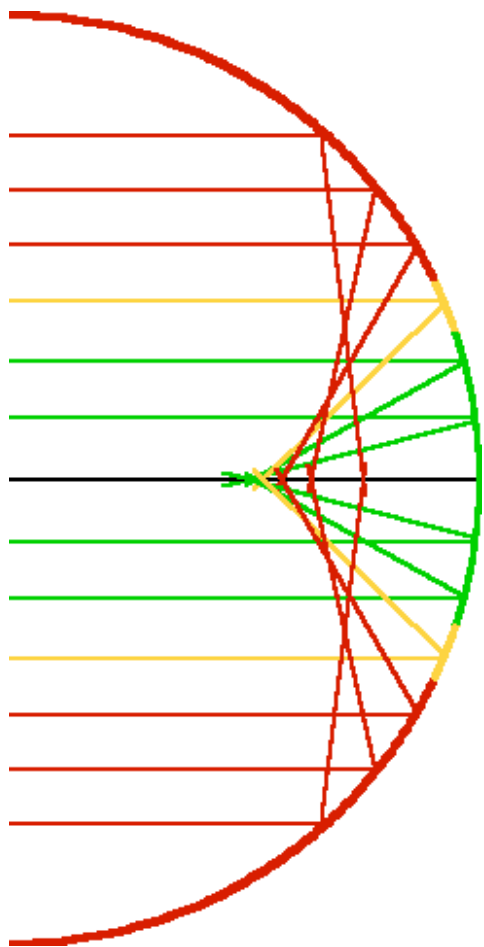

2.3 spherical mirror

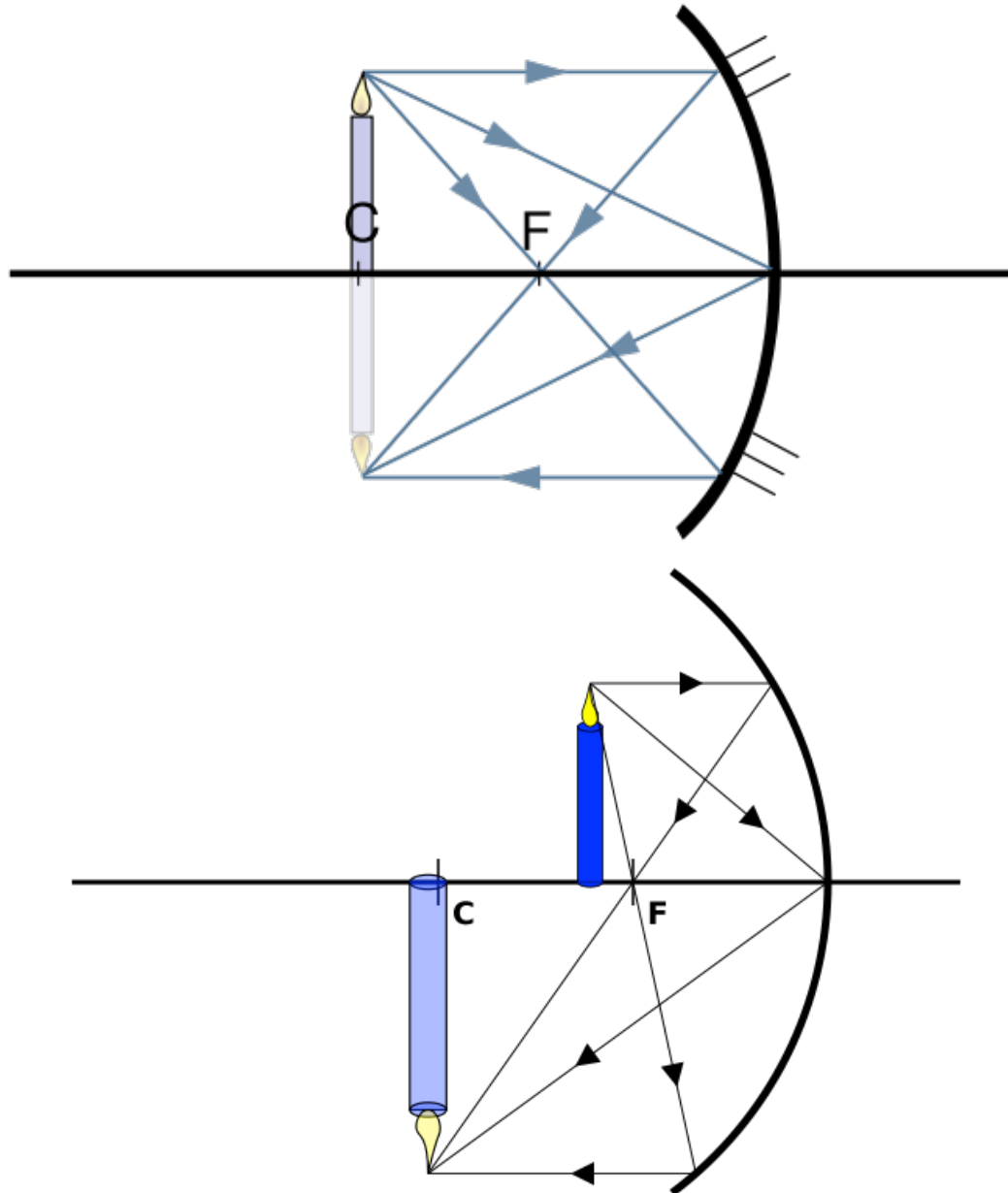

2.4 spherical refracting surfaces

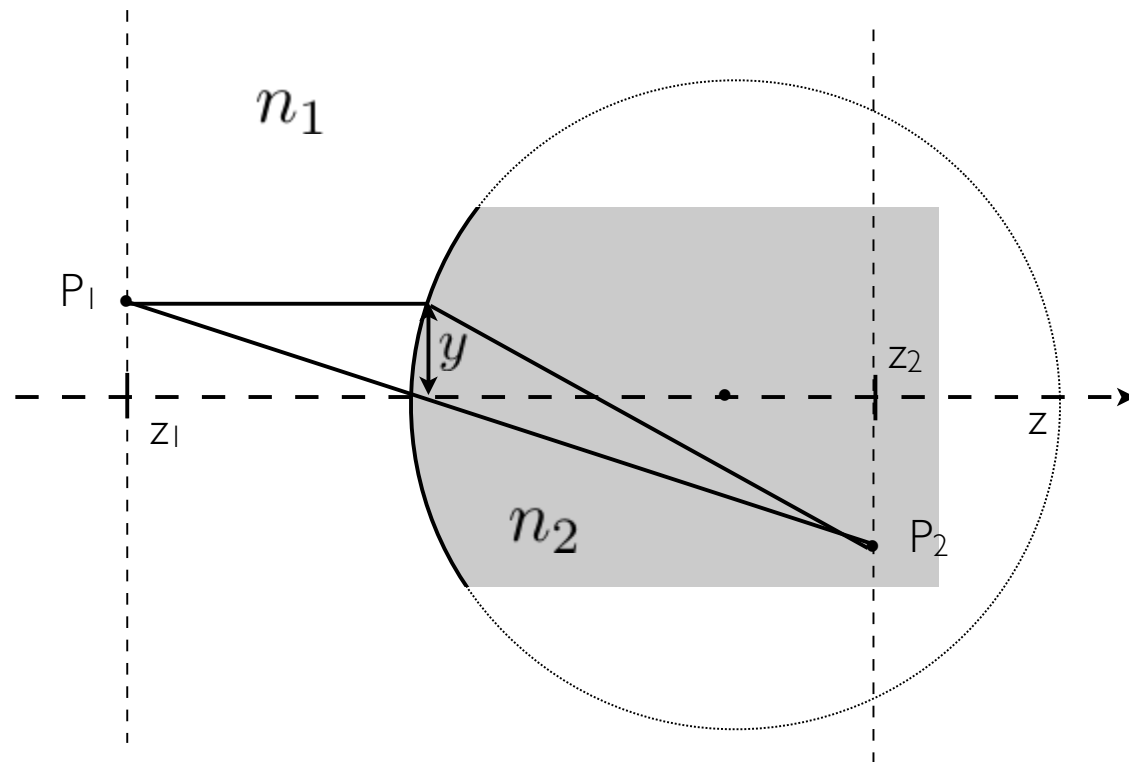

2.5 thin lens

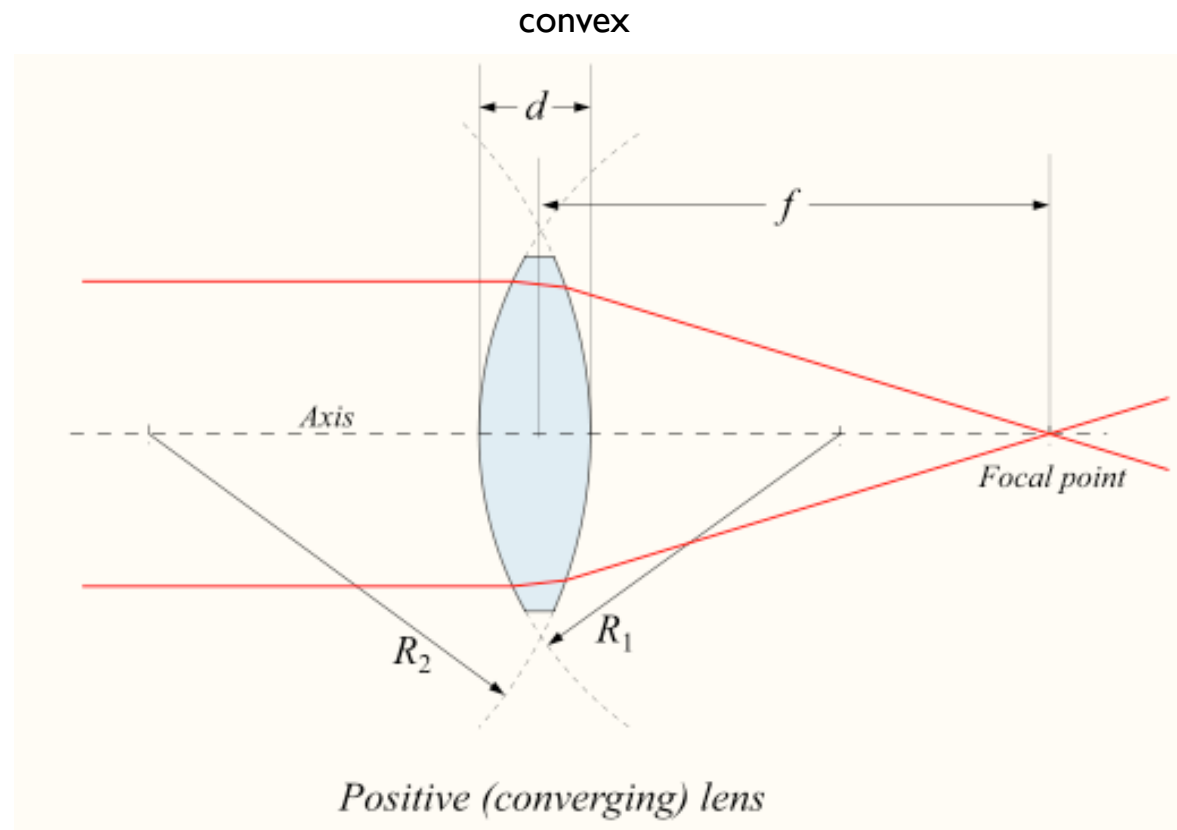

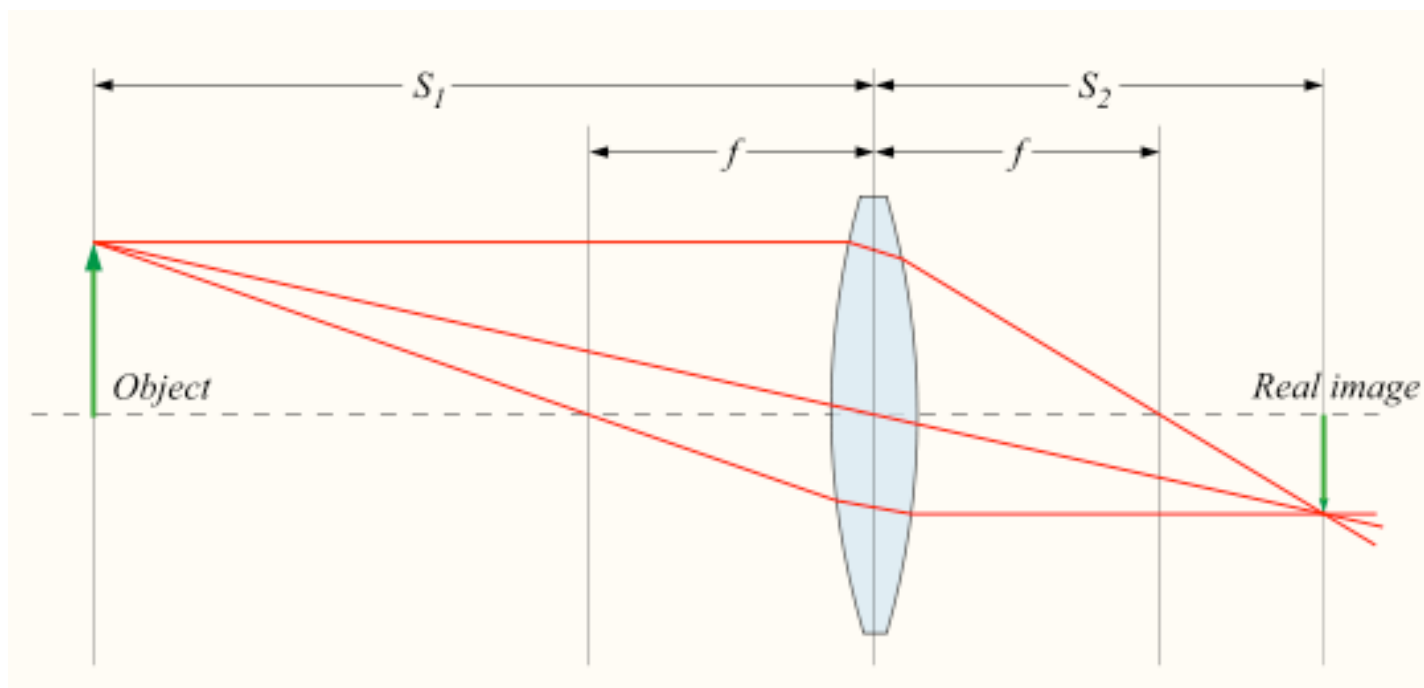

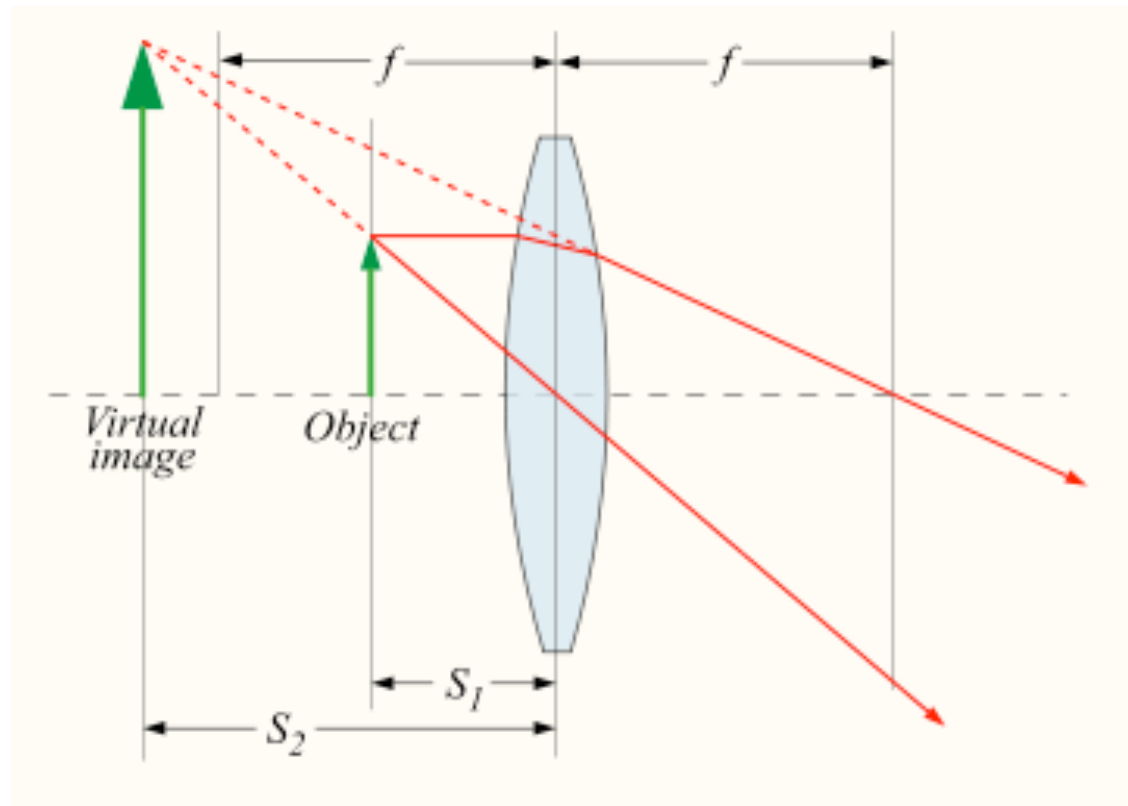

2.5 thin lens

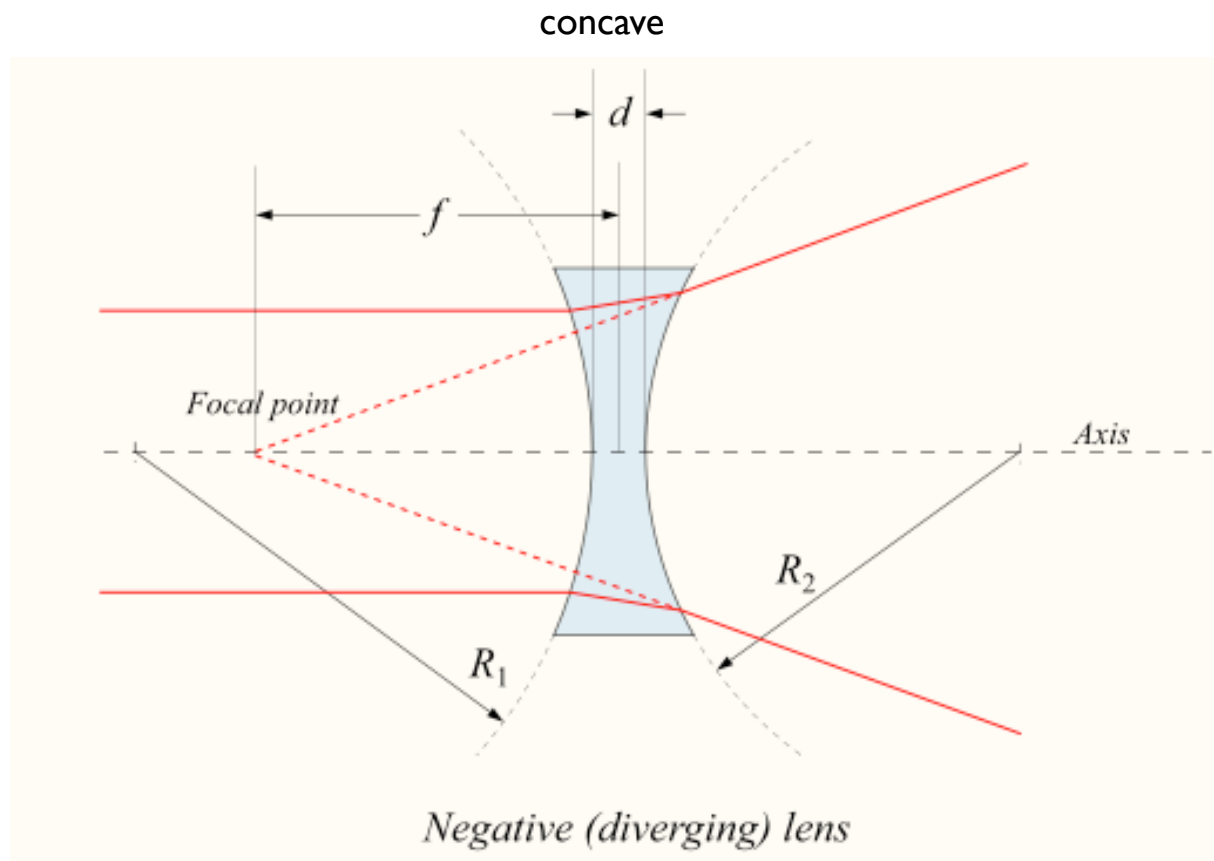

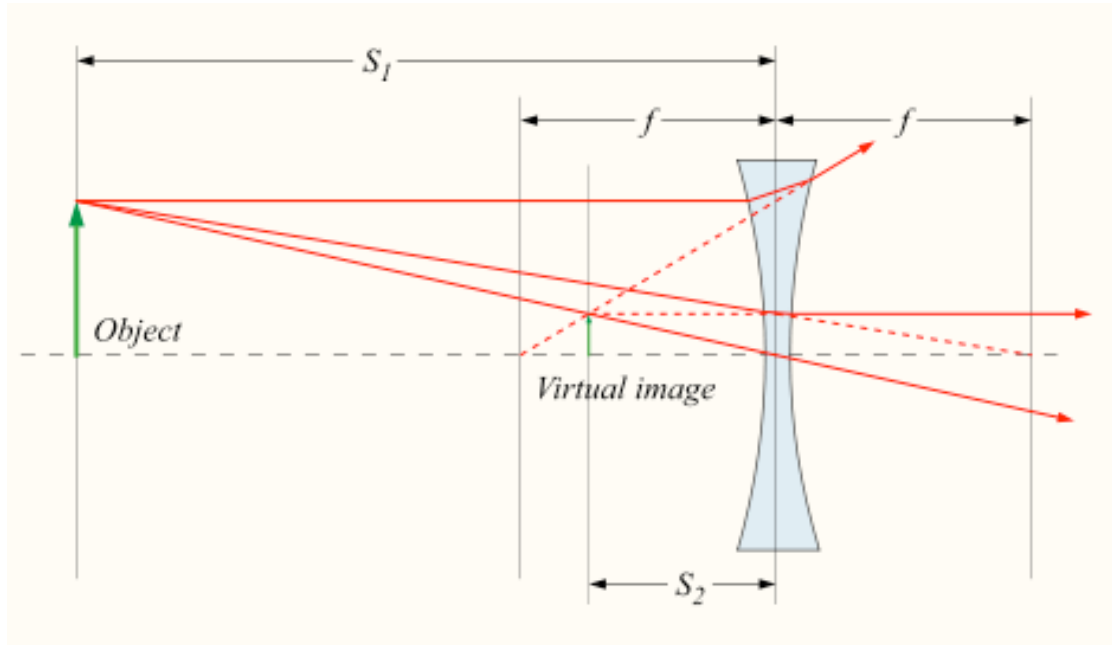

2.5 thin lens

